

Jehbsil® EXT#1446

SILICONE EXTRUSION MADE FOR GAP SEALING

Product description

Jehbsil® EXT#1446 is a silicone extrusion product manufactured for gap sealing applications in building projects. The product is made for high movement gaps and is designed to be used as an invisible seal.

Properties

The product is made from general purpose silicone and can be made in different colours as required.

Safety Notes

We recommend running preliminary tests to ensure the product material and cross-section profile suit the application and meet the desired performance criteria.

Product Cross-Section Dimensions And Tolerances

A general tolerance of $\pm 0.2\text{mm}$ is applied for all dimensions for the below profile:

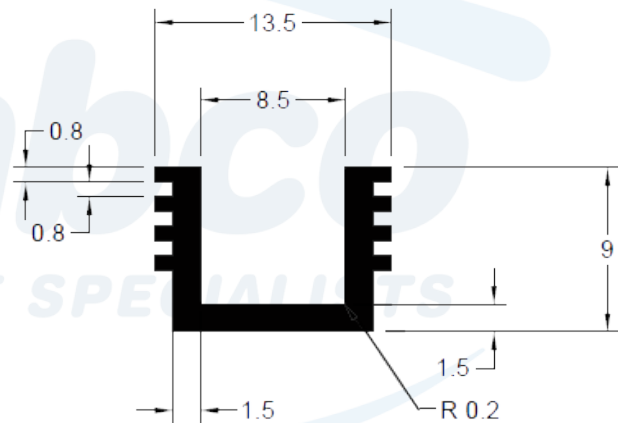

Product Data

Characteristics	Description
Material Composition	≈ %100 Silicone (Less than %1 of the material is pigment)
Colour	As Per Required
Density	1.13 (± 0.1) gr/cm^3
Temperature Range	-60°C to +230°C
Stability	UV and Ozone Resistant
Hardness	50 Duro
Tensile Strengths	11 MPa
Tear Strengths	21 N/mm
Elongation at Break	550%
Shelf life	20 Years